

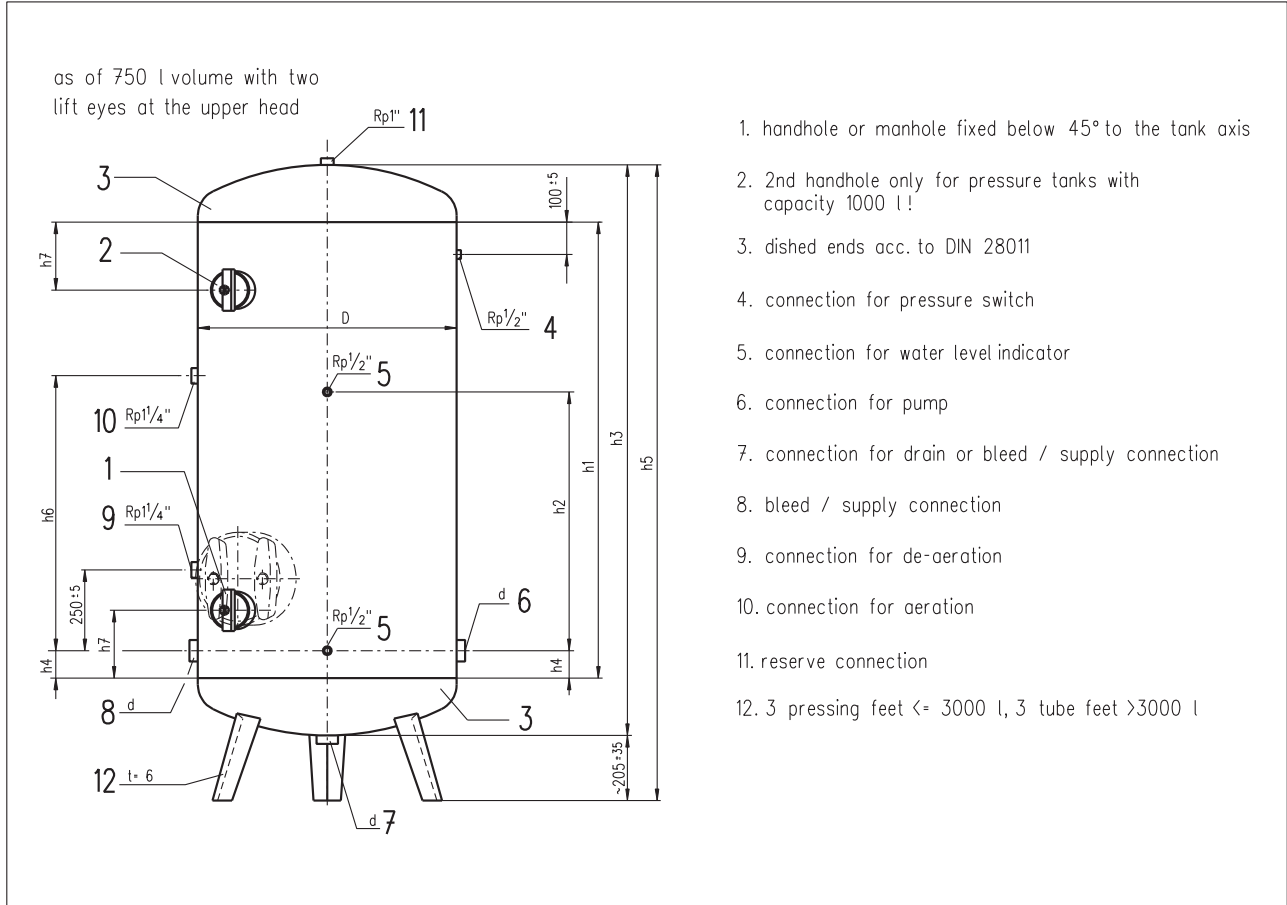

**Pressure vessel DIN 4810
hot-dip galvanized acc. DIN EN 10240**



volume in liter	item-no. with max. operating pressure			D	d	h1	h2	h3	h4	h5	h6	h7	handhole/manhole		~weight in kg		
	4 bar	6 bar	10 bar										qty.	size	4 bar	6 bar	10 bar
150	500200	500300	500500	450	Rp 2"	790	500	1010	85	1230	500	210	1	100x150	40	42	50
300	500202	500302	500502	550	Rp 2"	1100	700	1360	85	1570	675	210	1	100x150	62	64	85
500	500204	500304	500504	650	Rp 2"	1310	700	1610	85	1810	800	210	1	100x150	85	100	130
750	500206	500306	500506	800	Rp 2"	1250	700	1610	85	1810	800	210	1	100x150	110	143	185
1.000	500208	500308	500508	800	Rp 2"	1750	1000	2110	85	2310	1050	210	2	100x150	135	178	230
1.500	500210	500310	500510	1000	Rp 3"	1560	1000	2000	120	2200	1000	300	1	320x420	233	289	383
2.000	500212	500312	500512	1100	Rp 3"	1770	1000	2250	120	2450	1125	300	1	320x420	304	353	470
3.000	500214	500314	500514	1150	Rp 3"	2500	1000	3000	120	3200	1500	300	1	320x420	395	457	649
4.000	500216	500316	500516	1400	Rp 3"	2160	1000	2780	120	2980	1390	300	1	320x420	550	664	939
5.000	500218	500318	500518	1500	Rp 3"	2440	1000	3100	120	3300	1550	300	1	320x420	652	834	1162
6.000	500220	500320	500520	1500	Rp 3"	2990	1000	3650	120	3850	1825	300	1	320x420	728	938	1313
7.000	500222	500322	500522	1600	Rp 3"	3050	1000	3750	120	3950	1875	300	1	320x420	765	1089	1516
8.000	500224	500324	500524	1600	Rp 3"	3550	1000	4250	120	4450	2125	300	1	320x420	955	1199	1731
10.000	500226	500326	500526	1600	Rp 3"	4550	1000	5250	120	5450	2625	300	1	320x420	1117	1474	2015

suitable mediums: drinking water
 used material: steel, S235JR+N
 surface protection: inside + outside hot-dip galvanized
 operating temperature: 0 - 50 °C
 approval: CE; design tested up to 3.000 l
 basis for inspection: PED 2014/68/EU
 specification: AD 2000

purchase description (example):

DIN 4810, 300 l, 6 bar,
 item-no. 500302